

P6015 PROBE

*Please Check for
CHANGE INFORMATION
at the Rear of This Manual*

Copyright © 1963 , 1974 Tektronix, Inc. All rights reserved. Contents of this publication may not be reproduced in any form without the written permission of Tektronix, Inc.

Products of Tektronix, Inc. and its subsidiaries are covered by U.S. and foreign patents and/or pending patents.

TEKTRONIX, TEK, SCOPE-MOBILE, and  are registered trademarks of Tektronix, Inc. TELEQUIPMENT is a registered trademark of Tektronix U.K. Limited.

Printed in U.S.A. Specification and price change privileges are reserved.

INSTRUMENT SERIAL NUMBERS

Each instrument has a serial number on a panel insert, tag, or stamped on the chassis. The first number or letter designates the country of manufacture. The last five digits of the serial number are assigned sequentially and are unique to each instrument. Those manufactured in the United States have six unique digits. The country of manufacture is identified as follows:

B000000	Tektronix, Inc., Beaverton, Oregon, USA
100000	Tektronix Guernsey, Ltd., Channel Islands
200000	Tektronix United Kingdom, Ltd., London
300000	Sony/Tektronix, Japan
700000	Tektronix Holland, NV, Heerenveen, The Netherlands

NOTICE

Use only FLUOROCARBON 114 ($C_2 Cl_2 F_4$) as dielectric fluid. Use of other FLUOROCARBON fluids may develop dangerous pressures. Exceeding Voltage and Temperature specifications may result in dangerous internal pressures developed in the Probe body.



Fig. 1-1. P6015 Probe.

CHARACTERISTICS

Introduction

The P6015 High-Voltage Probe is a DC to 75 MHz, 1000X attenuator probe that adds high voltage capabilities to oscilloscopes or plug-in units with input resistances of 1 megohm and input capacitances of up to 60 picofarads (pF). The body of the P6015 Probe is made of a high-impact strength thermoplastic material that provides mechanical protection for the internal components of the probe and electrical protection for the user. The dielectric properties of the probe can be improved by filling it with flouorocarbon gas.

The complete standard probe assembly consists of the probe body, a 10-foot interconnecting cable with resistive center conductor, and the compensating box. Option 25 provides for a 25-foot overall length with reduced high-frequency performance characteristics.

Performance Conditions

The electrical characteristics listed in Table 1-1 are valid under the following conditions:

- The probe and the instrument with which it is used must have been calibrated at an ambient temperature of between +20°C and +30°C.

- The instrument and probe must be in an environment whose limits are described in Table 1-3.

Any conditions that are unique to a particular characteristic are expressly stated as a part of that characteristic.

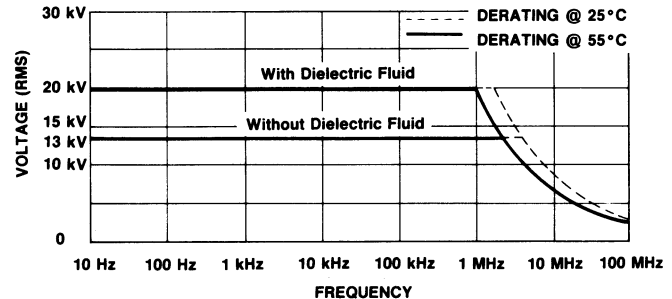

Fig. 1-2. Maximum input voltage derating with frequency.

**Table 1-1
Electrical Characteristics**

Characteristic	Performance Requirement	Supplemental Information
Attenuation	1000:1, variable by $\pm 5\%$.	Oscilloscope input: $1\text{ M}\Omega \pm 2\%$.
Voltage/Temperature Coefficients	(0 V to 20 kV, $+10^\circ\text{C}$ to $+55^\circ\text{C}$.) Total change typically $< \pm 1\%$. (0 V to 40 kV, $+10^\circ\text{C}$ to $+55^\circ\text{C}$.) Total change typically $< \pm 1.5\%$.	Temperature coefficient is typically $< \pm 0.006\%/^\circ\text{C}$. Voltage coefficient is typically $< \pm 0.018\%/^\circ\text{C}$.
Input Resistance	100 megohms.	Typically within $\pm 2\%$.
Input Capacitance		
10-foot probe	Approximately 3 pF.	Typically within $\pm 0.3\text{ pF}$.
25-foot probe	Approximately 4 pF.	Typically within $\pm 0.4\text{ pF}$.
Compensation Range	15 pF to 60 pF.	
Bandwidth (-3 db)		
10-foot probe	75 MHz.	Test oscilloscope must be $\geq 100\text{ MHz}$.
25-foot probe	8 MHz.	
Delay Time		
10-foot probe	Approximately 10 ns.	
25-foot probe	Approximately 25 ns.	

**Table 1-1 (cont.)
Electrical Characteristics**

Characteristic	Performance Requirement	Supplemental Information
Risetime		
10-foot probe	≤ 4.5 ns.	$Z_{\text{Source}} = 25$ ohms.
25-foot probe	≤ 50 ns.	
Aberrations		
10-foot probe	After 1st 5 ns, +4%, -4%, in addition to system aberrations.	
25-foot probe	After 1st 5 ns, +5%, -5%, in addition to system aberrations.	
Input Volts		
With flourocarbon dielectric fluid		
Arc-over Test		Leakage currents < 10 μ A at 27.5 kV dc.
Corona Test		Corona current < 1 μ A at 40 kV (10 kHz to 1 MHz).

**Table 1-1 (cont.)
Electrical Characteristics**

Characteristic	Performance Requirement	Supplemental Information
Maximum Input Volts (DC or RMS)	20 kV, dc to 1 MHz. ^a	Refer to Figure 1-2 for frequencies above 1 MHz.
Maximum Input Volts (Peak)	40 kV peak pulse. ^a Maximum duration: 100 ms. Maximum duty factor: 10%.	
Without dielectric fluid		
Maximum Input Volts (DC or RMS)	13 kV, dc to 2 MHz. ^a	Refer to Figure 1-2 for frequencies above 2 MHz.
Maximum Input Volts (Peak)	18 kV peak pulse. ^a Maximum duration: 100 ms. Maximum duty factor: 10%.	

^aThis Performance Requirement is not checked in the manual.

**Table 1-2
Physical Characteristics**

Characteristic	Description
Diameter	3.5 in. (8.8 cm.) max.
Length (Probe Body)	13.5 in. (34.3 cm) max.
Length (Cable)	10 ft. ± 2 in. (305 cm. ± 5.1 cm.)
	25 ft. ± 3 in. (762 cm. ± 7.6 cm.)
Dimensions (Compbox)	1.8 × 1.6 × 3.6 in. (46 × 41.3 × 905 cm.)
Saturation Pressure of Inert Gas	Approximately 2 atmospheres at 25°C (internal).
	Approximately 6 atmospheres at 75°C (internal).
Net Weight (Probe Assembly)	10 ft.: 1.8 lbs (0.82 kg.)
	25 ft.: 2.1 lbs (0.96 kg.)
Shipping Weight (Including Accessories)	10 ft.: 3.7 lbs (1.573 kg.) maximum.
	25 ft.: 4.0 lbs (1.713 kg.) maximum.

**Table 1-3
Environmental Characteristics**

Characteristic	Description
Temperature	<p>Non Operating: -55°C to $+55^{\circ}\text{C}$ (-67°F to $+131^{\circ}\text{F}$).</p> <p>Operating: -10°C to $+55^{\circ}\text{C}$ ($+14^{\circ}\text{F}$ to $+131^{\circ}\text{F}$). Per Tek Standard 062-2847-00, Class 3. Exception from Class 3 ($+55^{\circ}\text{C}$ to $+75^{\circ}\text{C}$).</p>
Humidity	<p>Operating and Non Operating: Five cycles (120 hr. total) at 95% to 97% relative humidity. Per Tek Standard 062-2847-00, Class 3.</p>
Altitude	<p>Non Operating: To 15,000 meters (50,000 feet).</p> <p>Operating: To 4,500 meters (15,000 feet). Tek Standard 062-2847-00.</p>
Vibration	<p>Operating: 0.64 mm (0.025 in.) p-p displacement, swept 10 Hz to 55 Hz in three axes, 75 minute total. Tek Standard 062-2858-00. Exception 400 g's.</p>
Shock	<p>Non Operating: 400 g's, half-sine, 0.5 ms duration, 18 shocks total in 3 axes. Tek Standard 062-2858-00. Exception 400 g's.</p>
Packaged Product Vibration and Shock	<p>The packaged product qualifies under the National Safe Transit Association's Pre-shipment Test Procedures, Project 1A-B-1, 48-inch drop. Tek Standard 062-2858-00.</p>

OPERATING INSTRUCTIONS

Low-Frequency Compensation

Due to variations in oscilloscope input capacitance, the low-frequency compensation of the P6015 should be checked, and adjusted if necessary, each time it is used with a different oscilloscope or oscilloscope input channel.

To do this, connect the P6015 to a 1 kHz square wave signal of enough amplitude to display 4 or 5 divisions on the oscilloscope (40 V or 50 V at 10 mV/div.). Some oscilloscopes have a Calibrator output suitable for this purpose, or else a Tektronix PG506 High Amplitude Square Wave Generator^a may be used. When using an oscilloscope calibrator, connect the P6015 probe-body ground-lead clip to the oscilloscope ground, and connect the P6015 tip to the calibrator. When using a PG506, connect a BNC male-to-GR adapter (Tektronix Part No. 017-0064-00) to the PG506 High Amplitude output connector and clip the P6015 ground lead to the outer fin of the GR connector. Insert the P6015 probe tip into the center conductor of the GR adapter.

^aRequires a TM500- or TM5000-Series Power Module Mainframe.

WARNING

The PG506 High Amplitude Square Wave Generator will produce up to 108 V from a 600 Ω source. To avoid personal injury, do not touch the GR center conductor or the P6015 tip while they are connected to the generator, or else electrical shock could result.

Adjust the signal source and oscilloscope volts/div for 4 or 5 divisions. Using a low-capacitance screwdriver, adjust C3 through the proper hole in the compensating box for the best square wave display.

High-Frequency Compensation

The high-frequency compensation of the P6015 seldom requires adjustment. However, if the probe has excessive high-frequency aberrations, insufficient bandwidth, or can-

not be low-frequency compensated, complete adjustment is necessary. Refer to "Check and Adjustment Procedure" (Section 3).

Attenuation

The P6015 High-Voltage Probe is designed to provide an attenuation of 1000X when used on a 1 M Ω oscilloscope input. This attenuation is variable by about 10% by adjusting R5 through the proper hole in the compensating box. Attenuation accuracy can be further optimized by adjusting R5 while the P6015 is connected to a voltage standard in the desired voltage range of measurement, thus eliminating voltage coefficient effects on attenuation accuracy.

Using the P6015

When filled with Fluorocarbon 114 gas, the P6015 can be safely used to measure signals of 20 kV (dc or rms, 40 kV peak) up to 1 MHz. Without the gas, the maximum

input voltage derates to 13 kV (dc or rms, 18 kV peak) up to 1 MHz. Refer to Fig. 1-2 in the "Characteristics" Section for derating above 1 MHz. Information regarding the checking of the proper Fluorocarbon 114 level in the probe and recharging the probe can be found in "Maintenance" (Section 4).

When making amplitude measurements with the P6015 Probe, multiply the amplitude of the display by the attenuation factor of the probe (1000). Remember that component heating caused by changes in ambient temperature or high voltage will cause a slight change in calibration accuracy. With higher-frequency signals, such as fast transients, ringing may occur which will distort the actual waveform. This ringing is due to resonance occurring between the capacitance of the probe and the ground lead inductance. It may be desirable in some cases to eliminate ringing caused by ground-lead inductance by removing the probe from its plastic body and building it directly into the circuit under test.

CHECK AND ADJUSTMENT PROCEDURE

Introduction

Complete calibration is given in this section. The P6015 can be returned to original performance by completion of this procedure. Limits, tolerances, and waveforms in this procedure are given as calibration guides, and are not instrument specifications.

To ensure accuracy, the probe should be checked and recalibrated periodically.

Test Equipment Required

The test equipment listed in Table 3-1, or its equivalent, is required for completion of this procedure. If equipment is substituted, control settings or test equipment setup may need to be altered.

Any needed maintenance should be performed before proceeding with calibration. Troubles which become apparent during calibration should be corrected immediately.

Table 3-1
Test Equipment Required

Item	Minimum Requirements	Recommended Example	Application
Oscilloscope	Input Impedance: 1M Ω . Sensitivity: 1 mV/div. Bandwidth: ≥ 100 MHz.	Tektronix 7704A Oscilloscope with 7A13 (Vert.) and 7B80 (Horiz.) Plug-Ins.	All checks and adjustments.
Square Wave Generator	Risetime: ≤ 100 ns. Rep. Rate: 1 kHz. Amplitude: ≥ 40 V.	Tektronix PG506 ^a	All checks and adjustments except hf peaking (R3).

^aRequires a TM500- or TM5000-Series Power Module Mainframe.

**Table 3-1 (cont.)
Test Equipment Required**

Item	Minimum Requirements	Recommended Example	Application
Square Wave Generator	Risetime: ≤ 10 ns. Rep. Rate: 1 MHz. Amplitude: ≥ 4 V.	Tektronix PG506 ^a (used with 50 Ω termination).	HF peaking adjustment (R3).
BNC Male-to-GR 50 Ω Termination Adapter		Tektronix Part No. 017-0083-00.	HF peaking adjustment (R3).
BNC Male-to-GR Adapter		Tektronix Part No. 017-0064-00.	All checks and adjustments except hf peaking (R3).
Low-Capacitance Screwdriver		Tektronix Part No. 003-0675-00.	All adjustments.

^aRequires a TM500- or TM5000-Series Power Module Mainframe.

Adjustment Description

The P6015 Compensating Box contains seven adjustable components. All except R5 (see schematic) vary the time constant of RC networks. The adjustable components and their effect on a 1 kHz square wave (see Fig. 3-1) are as follows:

C3—Part of an RC network that affects the leading corner of the square wave.

R1, C1—Comprise an RC network that affects the area immediately following the leading corner of the square wave.

R2, C2—Comprise an RC network that affects the middle section of the square wave.

R3—A high-frequency peaking adjustment that affects the leading 10 to 100 nanoseconds of a fast-rise pulse. The action of R3 will not be apparent

with signals having risetimes slower than 0.1 microsecond.

R5—An attenuation adjustment that varies output amplitude by about 10%. R5 may be used to eliminate voltage coefficient effects by adjusting the attenuation ratio against a known voltage standard in the desired voltage range.

Procedure

a. Connect a BNC male-to-GR adapter to the PG506 High Amplitude output connector. Connect the P6015 ground lead clip to the outer fin of the GR connector.

b. Insert the P6015 tip into the GR center conductor.

WARNING

The PG506 High Amplitude Square Wave Generator will produce up to 108 V from a 600 Ω source. To avoid personal injury, do not touch the GR center conductor or the P6015 tip while they are connected to the generator, or else electrical shock could result.

c. Connect the P6015 compensating box to the oscilloscope and set the oscilloscope volts/div to 10 mV/div.

d. Adjust the PG506 High Amplitude Generator for a 5-division display of 1 kHz on the oscilloscope.

e. If the waveform has aberrations, compensation is necessary. If the aberrations cannot be corrected by making minor adjustments, proceed as follows:

1. Preset C3 fully clockwise and back off 90°.

2. Preset C1 fully clockwise and back off 90°.

3. Preset R1 fully clockwise and back off 90°.

4. Preset C2 fully clockwise and back 2 turns.

5. Preset R2 fully clockwise and back off 90°.

f. Adjust R5 for the proper amplitude, based on the amplitude of the square wave and attenuation factors (oscilloscope volts/div \times 1000 P6015 attenuation). Use the level portions of the square wave if the waveform is over- or under-compensated.

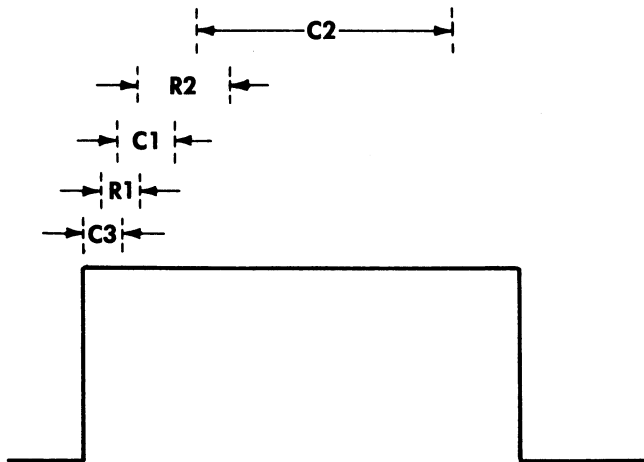

Fig. 3-1. Pulse area affected by each compensation adjustment.

g. Set the oscilloscope time/div to $50 \mu\text{s}/\text{div}$ and display the leading corner of the square wave. Adjust R1, C3 and C1 for the sharpest front corner without overshoot (see Fig. 3-1). Each may have to be adjusted several times for the sharpest corner. Maintain a front-corner amplitude that is consistent with the rest of the square wave. The R1-C3 combination affects the very corner and C1 affects the area immediately following, with some overlap.

h. Set the oscilloscope time/div to $0.2 \text{ ms}/\text{div}$ and adjust R2 and C2 to level the trailing 2 divisions of the top of the square wave.

i. With the time/div set to $0.2 \text{ ms}/\text{div}$, adjust C3 and C1 for a flat top on the square wave.

j. Any remaining aberrations may be corrected by slight readjustment of C1, R2, C2, R1, and C3.

k. Set the PG506 Amplitude control to minimum.

l. Replace the BNC-to-GR adapter with the BNC-to-GR 50Ω Termination Adapter.

m. Set the oscilloscope volts/div to $1 \text{ mV}/\text{div}$ and the time/div to $0.1 \mu\text{s}/\text{div}$.

n. Adjust the PG506 controls for a 5-division, 1 MHz square wave.

o. Adjust R3 as far as possible in the counter-clockwise direction without causing overshoot on the front corner.

This completes the procedure. Disconnect all test equipment.

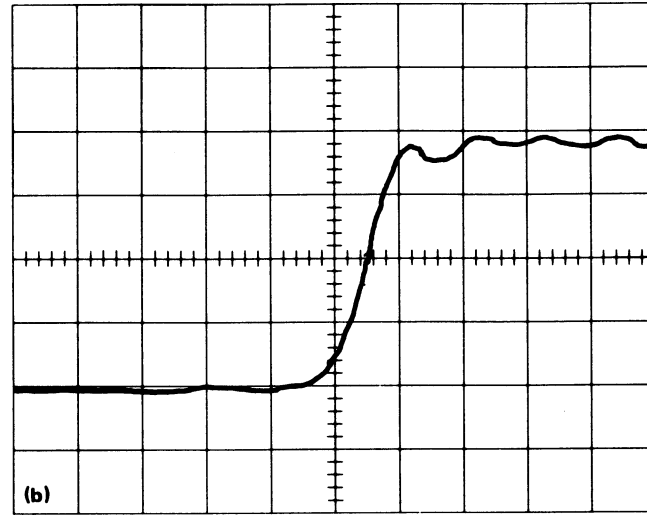
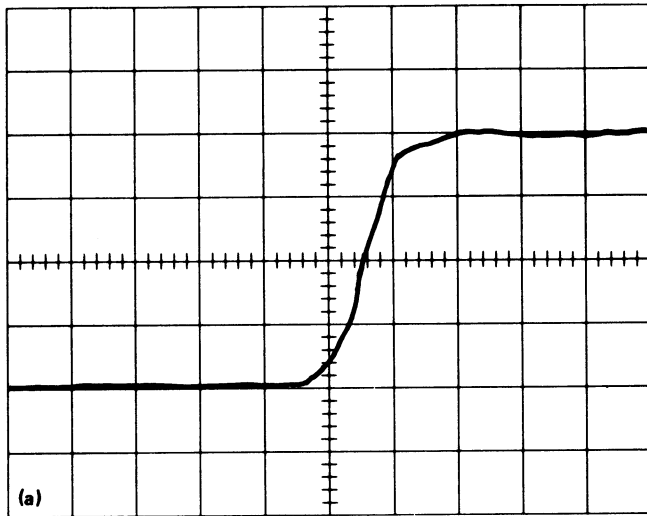

Fig. 2-2. Waveforms showing (a) Typical example of risetime within the probe's capability; and (b) example of risetime exceeding the probe's capability.

MAINTENANCE

Introduction

Normally, the P6015 Probe requires very little maintenance except for a visual and operational check. This section is provided as a maintenance guide, and contains procedures for visual inspection, recharging the probe with dielectric fluid, and troubleshooting.

Visual Inspection

A thorough visual inspection of the probe should be performed periodically. Look for such things as loose or broken connections, damaged plastic insulators, and proper dielectric fluid level. Except for low fluid level, the remedy for most of these troubles is apparent.

Check the dielectric fluid level by holding the probe with the tip down. The bottom of the Liquid Quantity Indicator should be approximately even with the bottom of the plastic body cover. If not, it is essential that the cause of the fluid loss be determined before adding more. Temperature as well as a leak could affect the liquid level. See "Recharging the Probe" for details and procedures for adding fluid.

WARNING

Use only Fluorocarbon 114 (C₂ CL₂ F₄) dielectric fluid. Use of other Fluorocarbon fluids may cause excessive internal pressures to develop.

Recharging the Probe

Fluorocarbon 114 has a saturation pressure of about 2 atmospheres at room temperature. At room temperature, a small amount of liquid should be visible through the transparent nose of the probe when the probe tip is pointed down. Any liquid visible in the nose is an indication of proper pressure inside the probe. The saturation pressure increases with temperature, and at higher temperatures it is normal for all of the Fluorocarbon 114 to be in a gaseous state. The top of the Liquid Quantity Indicator, at room temperature, should be approximately 3/16" (0.187 inch) below the bottom of the metal shield sleeve (see Fig. 4-1).

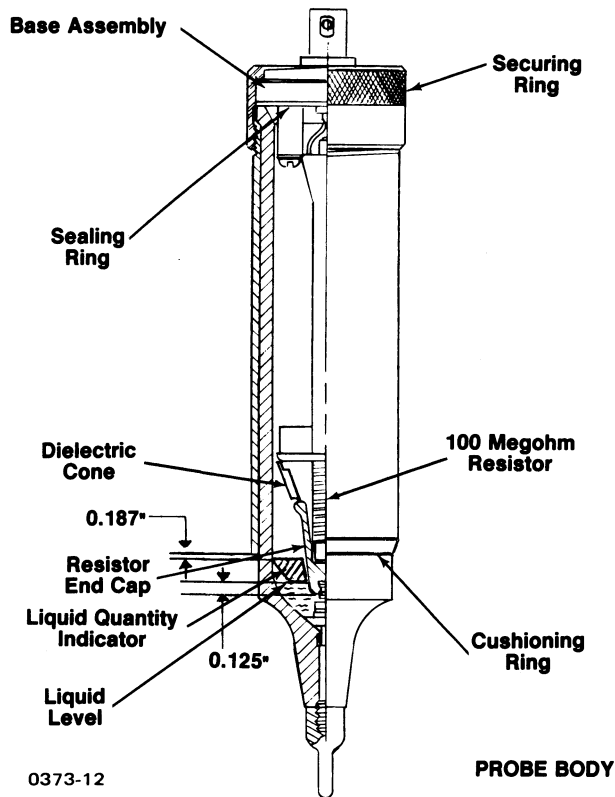

0373-12

Fig. 4-1. Cutaway view of the P6015 Probe.

Recharging the probe with Fluorocarbon 114 requires no special tools or equipment besides the dispenser supplied with each probe. If the liquid level in the probe is low, it can be recharged as follows:

1. Uncouple the two halves of the probe body cover and remove the cushion ring (see Fig. 4-1).
2. Unscrew and remove the securing ring.
3. Remove the base assembly from the probe body.
4. Hold the probe tip down and release Fluorocarbon 114 into the probe body until the liquid level is approximately 1/8" (0.125 inch) above the small end of the gold-plated resistor end cap (see Fig. 4-1).
5. Replace the base assembly. Be sure the 100 MΩ resistor is properly mated. Screw on the securing ring (hand tight — 50-60 inch-lbs.).
6. Shake the probe body to agitate the liquid; this accelerates vaporization and quickly builds up pressure inside the probe body.

7. Check that the top of the Liquid Quantity Indicator is approximately 3/16" (0.187 inch) below the bottom of the metal shield sleeve. If too much liquid boiled away, add more. If the liquid level is too high, bleed off excess by loosening the securing ring and letting the liquid boil. When the proper level has been reached, retighten the securing ring.
8. Replace the cushion ring on the probe body prior to reassembling the probe body and probe body cover.

Troubleshooting

Following are some possible trouble symptoms and causes.

No Output or Differentiated Output. Check R6, the center conductor of the interconnecting cable, and R100 in

the probe body. Replace the defective component. If R100 is defective, gain access to it as outlined in steps 1 through 3 under "Recharging the Probe".

Erroneous Attenuation Ratio. If there is an obvious error in attenuation, check resistors R3, R4, and R5. To gain access to the resistors, remove the compensating box cover by unscrewing the two screws on the top of the compensating box. Replace or reconnect components as indicated by the type of trouble.

Probe Cannot Be Compensated. Check capacitors C1, C2, and C3. Check resistors R1 and R2. If any of the capacitors are shorted, the attenuation ratio of the probe will be substantially changed. If the connections to the capacitors are faulty, or if the resistors are faulty, the defective component will not adjust properly when compensating the probe. Open the compensating box by unscrewing the two screws on the top and removing the cover. Reconnect or replace components as necessary.

OPTIONS

Option 10—P6015 without flourocarbon 114 dielectric fluid.

Option 25—P6015 with a 25-foot cable.

Option 26—P6015 with a 25-foot cable and without flourocarbon 114 dielectric fluid.

PARTS LIST AND SCHEMATIC

PARTS ORDERING INFORMATION

Replacement parts are available from or through your local Tektronix, Inc. Field Office or representative.

Changes to Tektronix instruments are sometimes made to accommodate improved components as they become available, and to give you the benefit of the latest circuit improvements developed in our engineering department. It is therefore important, when ordering parts, to include the following information in your order: Part number, instrument type or number, serial number, and modification number if applicable.

If a part you have ordered has been replaced with a new or improved part, your local Tektronix, Inc. Field Office or representative will contact you concerning any change in part number

FIGURE AND INDEX NUMBERS

Items in this section are referenced by figure and index numbers to the illustrations

ITEM NAME

In the Parts List, an Item Name is separated from the description by a colon (:). Because of space limitations, an Item Name may sometimes appear as incomplete. For further Item Name identification, the U.S. Federal Cataloging Handbook H6-1 can be utilized where possible.

INDENTATION SYSTEM

This mechanical parts list is indented to indicate item relationships. Following is an example of the indentation system used in the description column.

1 2 3 4 5 *Name & Description*

Assembly and/or Component

Attaching parts for Assembly and/or Component

---*---

Detail Part of Assembly and/or Component

Attaching parts for Detail Part

---*---

Parts of Detail Part

Attaching parts for Parts of Detail Part

---*---

Attaching Parts always appear in the same indentation as the item it mounts, while the detail parts are indented to the right. Indented items are part of, and included with, the next higher indentation. The separation symbol ---*--- indicates the end of attaching parts.

Attaching parts must be purchased separately, unless otherwise specified.

CROSS INDEX—MFR. CODE NUMBER TO MANUFACTURER

Mfr. Code	Manufacturer	Address	City, State, Zip
01121	ALLEN-BRADLEY COMPANY	1201 2ND STREET SOUTH	MILWAUKEE, WI 53204
02958	RUDD PAINT AND VARNISH COMPANY	1608 15TH WEST	SEATTLE, WA 98119
03888	KDI PYROFILM CORPORATION	60 S JEFFERSON ROAD	WHIPPANY, NJ 07981
05276	ITT, POMONA ELECTRONICS DIVISION	P O BOX 2767, 1500 E 9TH ST.	POMONA, CA 91766
12697	CLAROSTAT MFG. CO., INC.	LOWER WASHINGTON STREET	DOVER, NH 03820
32997	BOURNS, INC., TRIMPOT PRODUCTS DIV.	1200 COLUMBIA AVE.	RIVERSIDE, CA 92507
50293	GENERAL ELECTRIC COMPANY, INSTALLA- TION AND SERVICE ENGINEERING DEPT.	1 RIVER ROAD	SCHENECTADY, NY 12306
52769	SPRAGUE GOODMAN ELEC., INC.	134 FULTON AVENUE	GARDEN CITY PARK, NY 11040
63060	VICTOREEN INSTRUMENT, DIV. OF VLN CORP.	10101 WOODLAND AVE.	CLEVELAND, OH 44104
71590	CENTRALAB ELECTRONICS, DIV. OF GLOBE-UNION, INC.	P O BOX 858	FORT DODGE, IA 50501
72136	ELECTRO MOTIVE CORPORATION, SUB OF INTERNATIONAL ELECTRONICS CORPORATION	LAUTER AVE, P O BOX 7600	FLORENCE, SC 29501
73138	BECKMAN INSTRUMENTS, INC., HELIPOT DIV.	2500 HARBOR BLVD.	FULLERTON, CA 92634
73743	FISCHER SPECIAL MFG. CO.	446 MORGAN ST.	CINCINNATI, OH 45206
74868	BUNKER-RAMO CORP., THE AMPHENOL RF DIV.	33 E. FRANKLIN ST.	DANBURY, CT 06810
75042	TRW ELECTRONIC COMPONENTS, IRC FIXED RESISTORS, PHILADELPHIA DIVISION	401 N. BROAD ST.	PHILADELPHIA, PA 19108
77900	SHAKEPROOF DIV OF ILLINOIS TOOL WORKS	SAINT CHARLES RD	ELGIN, IL 60120
78189	ILLINOIS TOOL WORKS, INC. SHAKEPROOF DIVISION	ST. CHARLES ROAD	ELGIN, IL 60120
80009	TEKTRONIX, INC.	P O BOX 500	BEAVERTON, OR 97077
83385	CENTRAL SCREW CO.	2530 CRESCENT DR.	BROADVIEW, IL 60153
91637	DALE ELECTRONICS, INC.	P. O. BOX 609	COLUMBUS, NE 68601
91836	KINGS ELECTRONICS CO., INC.	40 MARBLEDALE ROAD	TUCKAHOE, NY 10707
95548	MORRIS J I CO.	394 ELM ST	SOUTHBRIDGE, MA 01550
T1063	SCHOOF INC.	P O BOX 67	MORAGA, CA 94556



Fig. & Index No.	Tektronix Part No.	Serial/Assembly No. Effective Dscont	Qty	12345	Name & Description	Mfr. Code	Mfr. Part No.
1-1					PROBE		
-2	015-0049-00		1		.COMP,TEST PROD:HIGH VOLTAGE PROBE,BNC (STANDARD AND OPT;10)	80009	015-0049-00
	015-0039-00		1		.COMP,TEST PROD:HIGH VOLTAGE PROBE,UHF	80009	015-0039-00
	015-0525-00		1		.COMP,TEST PROD:HV,40KV (OPT;25 AND OPT;26)	80009	015-0525-00
-3	252-0120-00		1		.FREDN:3 OZ AEROSOL M/MSOS (STANDARD AND OPT;25)	02958	202X2124
	256-0570-00	7401	1		..DEHYDRATING AGT:SILICA GEL,2.75 DIA	53718	X-1009
-4	344-0005-00		1		.CLIP,ELECTRICAL:ALLIGATOR,2.5 L,M/PLUG & COVER	80009	344-0005-00
-5	352-0056-00		1		.HOLDER,PROBE:DELTRIN	80009	352-0056-00
-6	202-0139-00	6834	1		.CASE,CRYG,PROBE:	80009	202-0139-00
	334-4217-00		1		.PLATE,IDENT:MKD P6015,010-0172-00	80009	334-4217-00
	436-0035-00	6834	1		.TRAY,ACCESSORY:	80009	436-0035-00
	016-0128-00	6835 7401	1		.CASE,CRYG,PROBE:	80009	016-0128-00
	004-0217-00	7401	1		..PAD,CUSHIONING:POLYURETHANE,11.5 X 6.5	80009	004-0217-00
	016-0128-01	7402 7609	1		..CASE,CRYG,PROBE:	80009	016-0128-01
	016-0128-02	7610	1		..CASE,CRYG,PROBE:	80009	016-0128-02
	070-0373-01	7401	1		.MANUAL,TECH:INSTRUCTION,P6015	80009	070-0373-01
	070-0373-02	7402	1		.MANUAL,TECH:INSTRUCTION	80009	070-0373-02

PROBE

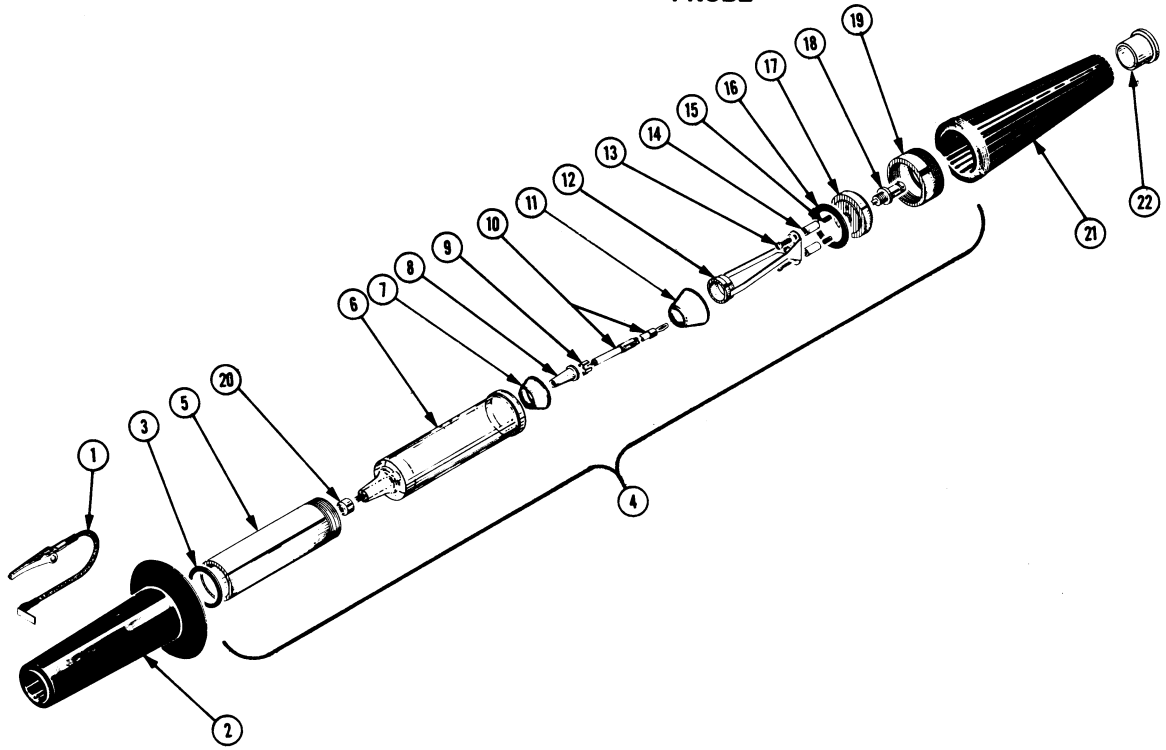

Fig. & Index No.	Tektronix Part No.	Serial/Assembly No.		Qty	12345	Name & Description	Mfr.	
		Effective	Dscont				Code	Mfr. Part No.
2-	010-0131-00			1		PROBE,VOLTAGE:120.0 L,1000X,40KV	80009	010-0131-00
	010-0131-02	8619		1		PROBE,VOLTAGE:OPT;25,303.0 L,40KV	80009	010-0131-02
-1	175-0192-00			1		.LEAD,ELECTRICAL:STRD,18 AWG,6.0 L	80009	175-0192-00
-2	204-0151-00		8511	1		.BODY,PROBE:OUTER	80009	204-0151-00
	204-0151-01	8512		1		.BODY,PROBE:OUTER,P6015,FINISHED	80009	204-0151-01
-3	354-0189-00			1		.RING,CUSHION:PROBE,BLACK VINYL	80009	354-0189-00
-4	204-0158-00			1		.BODY ASSY,PROBE:	80009	204-0158-00
	204-0158-02	8619		1		.BODY ASSY,PROBE:P6015 OPT 25/26	80009	204-0158-02
-5	166-0301-00			1		..SLEEVE,SHIELD:1.37 ID X 1.5 OD X 4.5 L,AL	80009	166-0301-00
-6	204-0157-00			1		..BODY ASSY,PROBE:INNER	80009	204-0157-00
-7	214-2427-00	7610		1		..IND,LIQUID QTY:FLUOROCARBON,PROBE	80009	214-2427-00
-8	337-0559-00			1		..SHIELD,RESISTOR:	80009	337-0559-00
-9	344-0091-00			1		..CLIP,ELECTRICAL:RESISTOR,CU BE	80009	344-0091-00
	214-0318-00		7609	1		..RES AND PL ASSY:	80009	214-0318-00
						...RESISTOR:(SEE R100 REPL)		
	134-0015-00		7609	1		...PLUG,TIP:BANANA,SMALL	05276	3271
-10	310-0597-00	7610		1		..RES,FXD,FILM:100 MEG OHM,2Z,50KV	63060	MOX-45P100MOHM1Z
-11	214-3926-00	8619		1		..CONE,DIELECTRIC:POLYSTYRENE NATURAL ..(OPTION 25 AND 26 ONLY)	80009	214-3926-00
-12	214-0310-00			1		..PLATE,CAPACITOR: ..(ATTACHING PARTS)	80009	214-0310-00
-13	211-0008-00			2		..SCREW,MACHINE:4-40 X 0.25,PNH,STL	93907	ORDER BY DESCR
-14	361-0046-00			2		..SPACER,POST:0.5 L,ACETAL,0.25 OD	80009	361-0046-00
-15	213-0115-00			2		..SETSCREW:4-40 X 0.312,STL	50293	ORDER BY DESCR
-16	354-0191-00			1		..GASKET:SEALING,1.17 ID X 1.445 OD,NPRN ..(END ATTACHING PARTS)	80009	354-0191-00
-17	358-0205-00		8505	1		..BUSHING,BASE:ALUMINUM	80009	358-0205-00
	358-0205-01	8506		1		..BUSHING,BASE:ALUMINUM	80009	358-0205-01
-18	131-0264-00			1		..CONN,RCPT,ELEC:BNC,FEMALE,PRESSURIZED	74868	31-102
-19	354-0190-00			1		..RING,SECURING:1.5-32 X 0.828,BRS CU-SN-ZN	80009	354-0190-00

Fig. & Index No.	Tektronix Part No.	Serial/Assembly No.		Qty	12345	Name & Description	Mfr.	
		Effective	Dscont				Code	Mfr. Part No.
2-20	206-0116-00			1		.TIP, PROBE:	80009	206-0116-00
-21	367-0034-00			1		.HANDLE, PROBE:5.915 L, NYLON, GRAY	80009	367-0034-00
-22	134-0068-00			1		.BUSHING, SLEEVE:0.691 ID X 2.5 00 X 0.7 L	80009	134-0068-00

COMPENSATING BOX

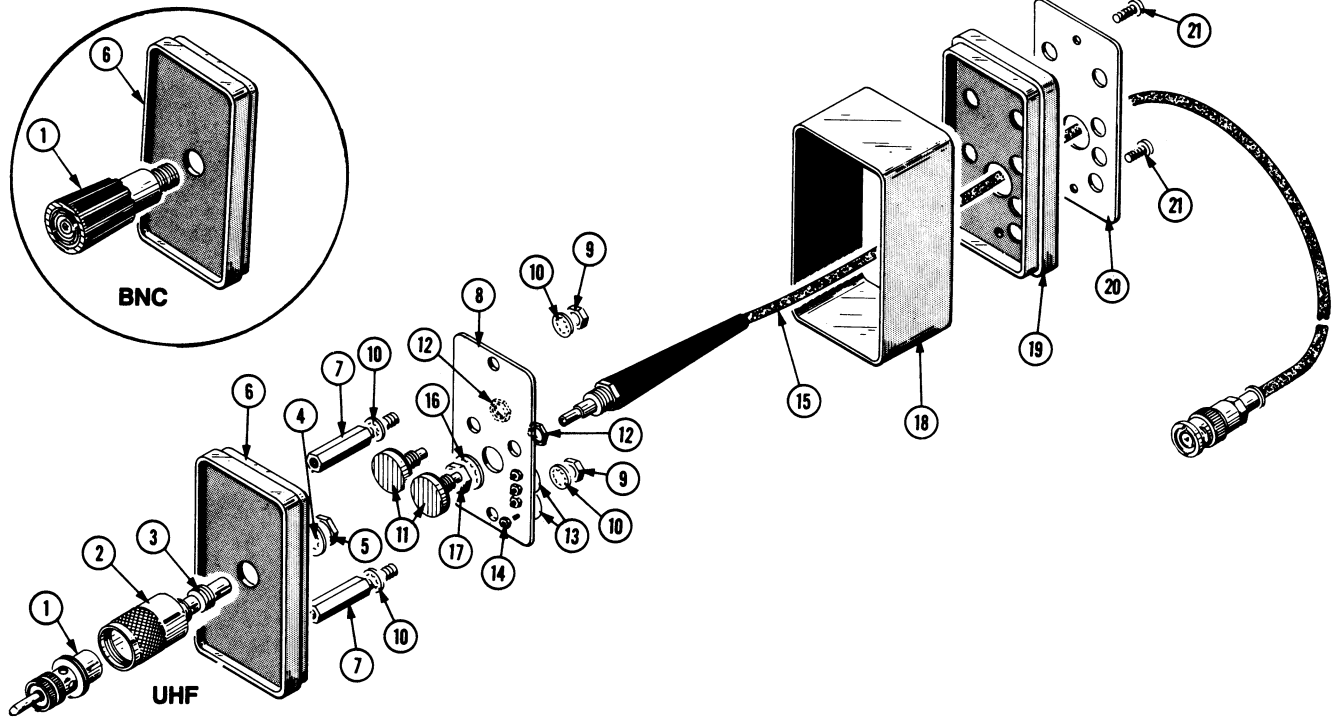
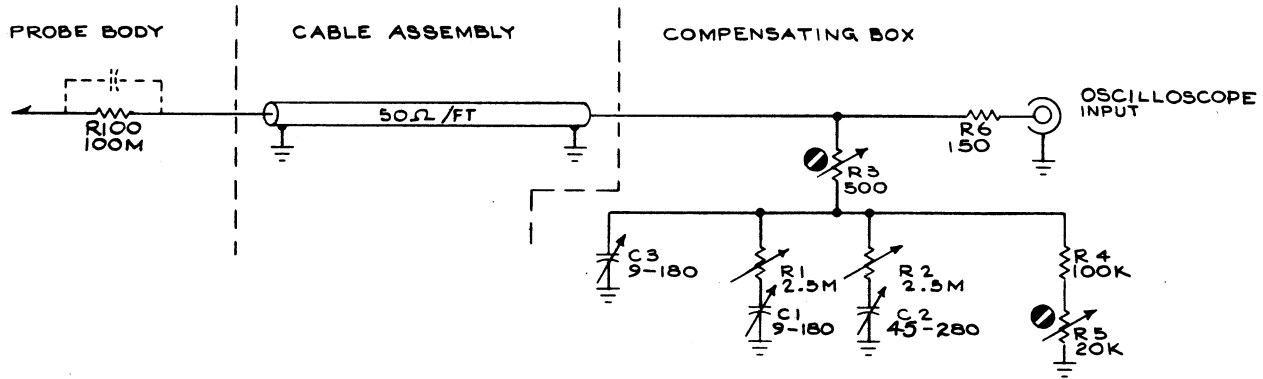

Fig. & Index No.	Tektronix Part No.	Serial/Assembly No.		Qty	12345	Name & Description	Mfr.	
		Effective	Dscont				Code	Mfr. Part No.
3-	015-0525-00			1	12345	COMP,TEST PROD:HV,40KV (OPTION 25 AND 26 ONLY)	80009	015-0525-00
	015-0039-00			1		COMP,TEST PROD:HIGH VOLTAGE PROBE,UHF	80009	015-0039-00
	015-0049-00			1		COMP,TEST PROD:HIGH VOLTAGE PROBE,BNC	80009	015-0049-00
-1	131-0168-00			1		.CONN,PLUG,ELEC:UHF,MALE,MODIFIED (015-0039-00 UHF)	80009	131-0168-00
	131-0319-01			1		.CONN,RCPT,ELEC:BNC,MALE (015-0049-00 BNC)	80009	131-0319-01
-2	200-0026-00			1		.SHELL,ELEC CONN:UHF MALE (015-0039-00 UHF)	91836	U-59-06-8M06
-3	102-0006-00			1		.BSHG,ELEC CNDOCT:REDUCER	80009	102-0006-00
-4	210-0012-00			1		.WASHER,LOCK:0.384 ID,INTL,0.022 THK,STL	09772	ORDER BY DESCR
-5	210-0413-00			1		.NUT,PLAIN,HEX:0.375-32 X 0.5,BRS CD PL	73743	3145-402
-6	200-0439-00			1		.COVER,BOX,REAR:	80009	200-0439-00
-7	361-0047-00			2		.SPACER,POST:1.171 L M/4-40 INT/EXT THD,AL	80009	361-0047-00
	210-0003-00			2		.WASHER,LOCK:#4 EXT,0.015 THK,STL	78189	1104-00-00-0541C
-8	441-0467-00			1		.CHAS,COMP BOX: (ATTACHING PARTS)	80009	441-0467-00
-9	210-0410-00			2		.NUT,PLAIN,HEX:10-32 X 0.312,BRS CD PL	73743	2X-2003-402
-10	210-0010-00			4		.WASHER,LOCK:#10 INTL,0.02 THK,STL (END ATTACHING PARTS)	77900	1210-00-00-0541C
-11	-----			2		.RES.,VAR:(SEE R1 AND R2 REPL) (ATTACHING PARTS)		
-12	210-0583-00			2		.NUT,PLAIN,HEX:0.25-32 X 0.312,BRS CD PL (END ATTACHING PARTS)	73743	2X-20319-402
-13	-----			2		.RES.,VAR:(SEE R3 AND R5 REPL) (ATTACHING PARTS)		
-14	210-0504-00			4		.NUT,PLAIN,HEX:0-80 X 0.156 HEX,BRS CD PL	80009	210-0504-00
	210-0065-00	7718		4		.WASHER,LOCK:#0 SPLIT,0.016 THK SST (END ATTACHING PARTS)	95548	ORDER BY DESCR

Fig. & Index No.	Tektronix Part No.	Serial/Assembly No. Effective Dscont	Qty	12345	Name & Description	Mfr. Code	Mfr. Part No.
3-	388-5719-00	7733	2		.CIRCUIT BOARD:VARIABLE RESISTOR (ATTACHING PARTS)	80009	388-5719-00
	211-0160-00	7733	4		.SCREW,MACHINE:0-80 X 0.188,FILH,SST	70318	ORDER BY DESCR
	210-1107-00	7733	4		.WASHER,FLAT:0.062 ID X 0.13 OD X 0.019,SST (END ATTACHING PARTS)	95548	ORDER BY DESCR
-15	175-0264-00		1		.CABLE ASSY,RF:50 OHM COAX,122.0 L (STANDARD AND OPTION 10 ONLY)	80009	175-0264-00
	174-0336-00		1		.CABLE ASSY,RF:26 OHM COAX,303.0 L (OPTION 25 AND 26 ONLY) (ATTACHING PARTS)	80009	174-0336-00
-16	210-0012-00		1		.WASHER,LOCK:0.384 ID,INTL,0.022 THK,STL	09772	ORDER BY DESCR
-17	210-0590-00		1		.NUT,PLAIN,HEX:0.375-32 X 0.438 BRS CD PL (END ATTACHING PARTS)	73743	28269-402
-18	380-0045-00		1		.HOUSING,COMP:ALUMINUM (015-0039-00 UHF)	80009	380-0045-00
	380-0069-00		1		.HOUSING,COMP:ALUMINUM (015-0049-00 AND 015-0525-00)	80009	380-0069-00
-19	200-0438-00		1		.COVER,BOX:FRONT	80009	200-0438-00
-20	200-0440-00		1		.COVER,COMP BOX:1.632 X 3.385,AL	80009	200-0440-00
-21	211-0071-00		2		.SCREW,MACHINE:4-40 X 0.375,TRH,STL	83385	ORDER BY DESCR
	210-0003-00		2		.WASHER,LOCK:#4 EXT,0.015 THK,STL	78189	1104-00-00-0541C

ELECTRICAL PARTS LIST

Component No.	Tektronix Part No.	Serial/Assembly No. Effective Dscont	Name & Description	Mfr. Code	Mfr. Part No.
C1	281-0023-00		CAP,VAR,MICA DI:9-180PF,175V	52769	GMA40300
C2	281-0044-00	8605	CAP,VAR,MICA DI:80-480PF,175V	52769	GMA 40600
C2	281-0275-00	8606	CAP,VAR,MICA DI:45-280PF,175V	52769	GMA 40400
C3	281-0023-00		CAP,VAR,MICA DI:9-180PF,175V	52769	GMA40300
R1	311-0325-00		RES,VAR,NONMM:PNL,2.5MEG OHM,0.25M	12697	381-CM39666
R2	311-0325-00		RES,VAR,NONMM:PNL,2.5MEG OHM,0.25M	12697	381-CM39666
R3	311-0150-00	7732	RES,VAR,NONMM:TRMR,500 OHM,0.1M	71590	BA305-016#6
R3	311-1564-00	7733	RES,VAR,NONMM:TRMR,500 OHM,0.5M	32997	3352T-CK5501
R4	309-0045-00	7345	RES,FXD,FILM:100K OHM,1%,0.5M	91637	DCS1231-10002F
R4	323-0385-00	7346	RES,FXD,FILM:100K OHM,1%,0.5M,TC=TO	75042	CECT0-1003F
R5	311-0337-00	7732	RES,VAR,NONMM:TRMR,20K OHM,0.1M	71590	BA305-036
R5	311-1558-00	7733	RES,VAR,NONMM:TRMR,20K OHM,0.5M	32997	3352T-1-203
R6	304-0151-00	6423	RES,FXD,CMPSN:150 OHM,10%,1M	01121	GB1511
R6	302-0151-00	6424	RES,FXD,CMPSN:150 OHM,10%,0.5M	01121	EB 1511
R100	310-0597-00		RES,FXD,FILM:100 MEG OHM,2%,50KV	63060	MOX-4SP100MOHM1%



PLM
163
P6015 PROBE

**ADDENDUM TO TEKTRONIX MATERIAL SAFETY DATA
FOR PART NUMBER 252-0120-00**

Because of an international agreement limiting chlorofluorocarbons, the 3-oz. can of HIGH VOLTAGE DI-ELECTRIC FLUID, Tektronix Part Number 252-0120-00, is no longer shipped with the Tektronix P6015 Voltage Probe. However, the material described in the attached Tektronix Material Safety Data Sheet; High Voltage Di-Electric Fluid, Dichlorotetrafluorethane, is contained in the body of the P6015 High Voltage Probe. Please comply with all safety precautions.